

DIW Berlin

Deutsches Institut
für Wirtschaftsforschung

www.diw.de

Convergence of Wholesale Electricity Prices in Europe?

- A Time Series Analysis of Hourly Spot Prices -

Georg Zachmann

7th IAEE European Energy Conference

Bergen, August 28–30th, 2005

Agenda

1. Aim of the Study and Literature

2. Data
3. Method
4. Results
5. Conclusion

Motivation

- Regulation 1228/2003/EC does not specify a preferable „market based congestion management method“
- Cross-border capacity auctions became standard in Central Europe
- Durable inefficient auction outcomes lead to inefficient trade flows and thus to welfare losses due to an international scheduling that is based on wrong price signals

Aim of the Study

- Test whether and how European electricity prices interact
- Test whether electricity wholesale prices are converging towards the law of one price
 - Develop a model based on the „law of one price“ for the interaction of European electricity prices
 - Develop an indicator of convergence
 - Test if there is significant convergence in the hourly prices

Literature

Armstrong, Margaret and Galli, Alain, 2005. Are day-ahead prices for electricity converging in continental Europe? An exploratory data approach. CERNA Working Paper.

Boisseleau, François, 2004. The role of power exchanges for the creation of a single European electricity market: market design and market regulation. Delft University Press.

Bower, John, 2002. Seeking the Single European Electricity Market: Evidence from an Empirical Analysis of Wholesale Market Prices. Economics Working Paper Archive at WUSTL.

1. Aim of the Study and Literature

2. Data

3. Method

4. Results

5. Conclusion

Data

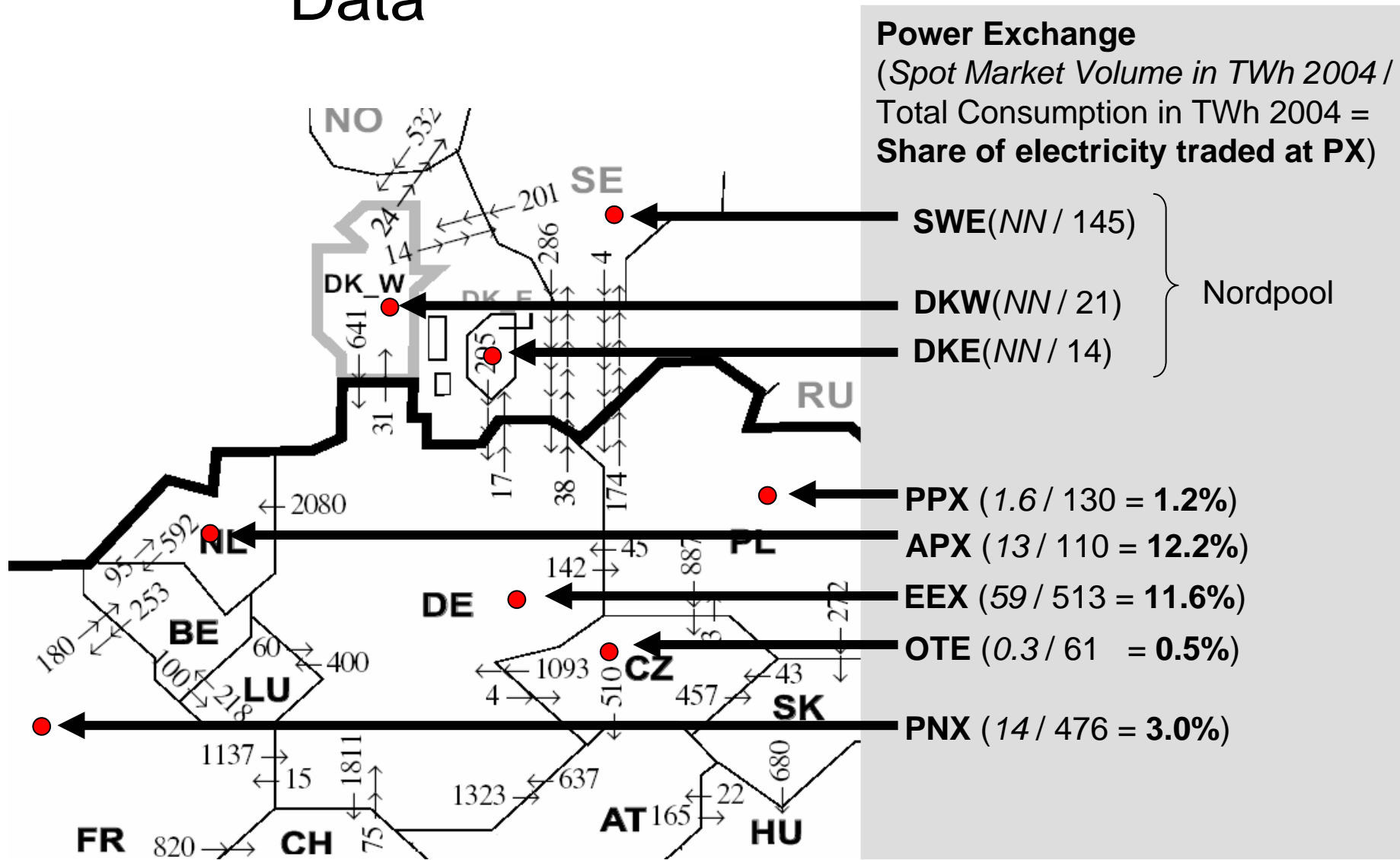

Intra-day Seasonalities

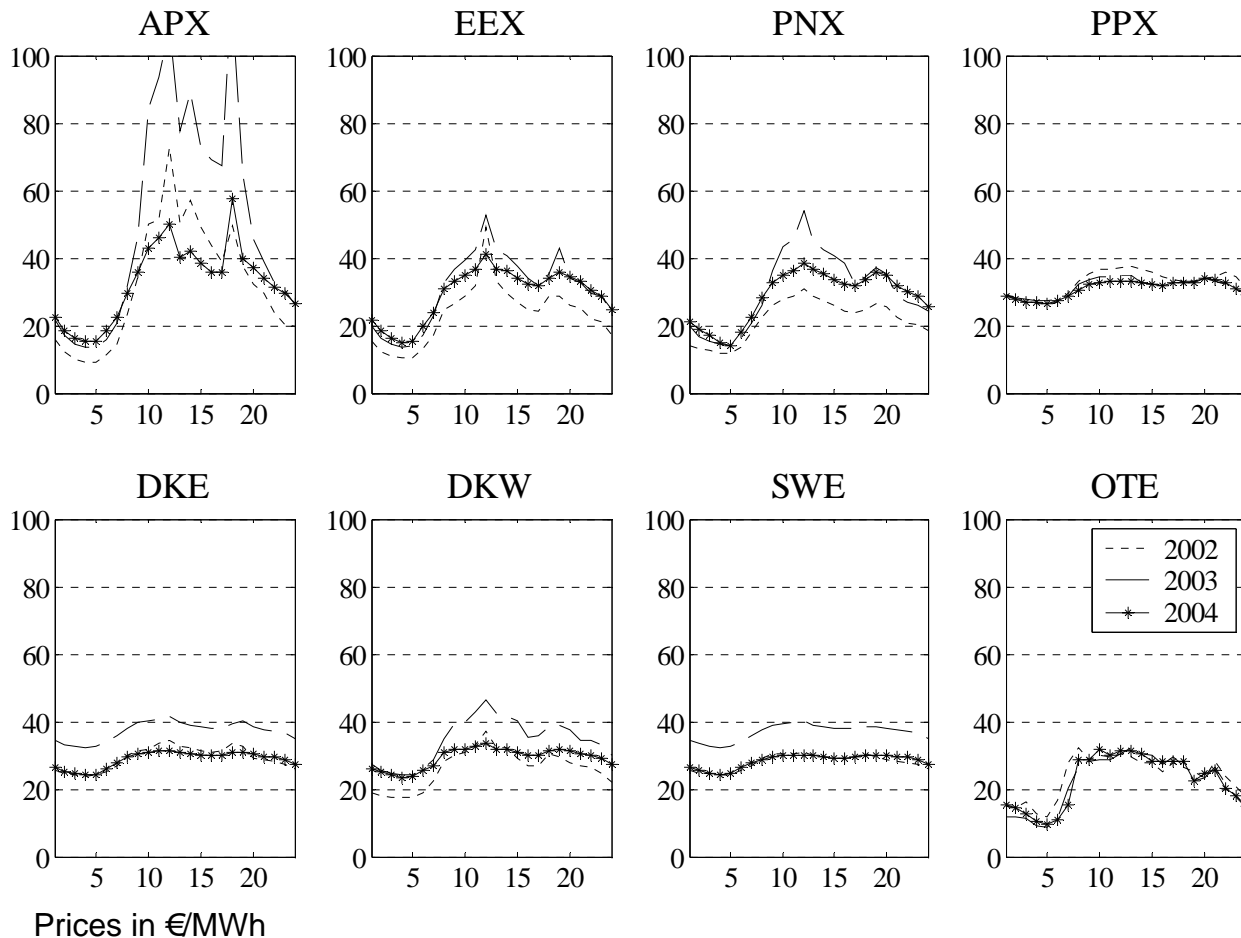

Strong seasonalities at APX

Moderate seasonalities at EEX, PNX, DKW and OTE

Minor seasonalities at DKE, SWE and PPX

Correlation of wholesale spot prices with their first and second common component

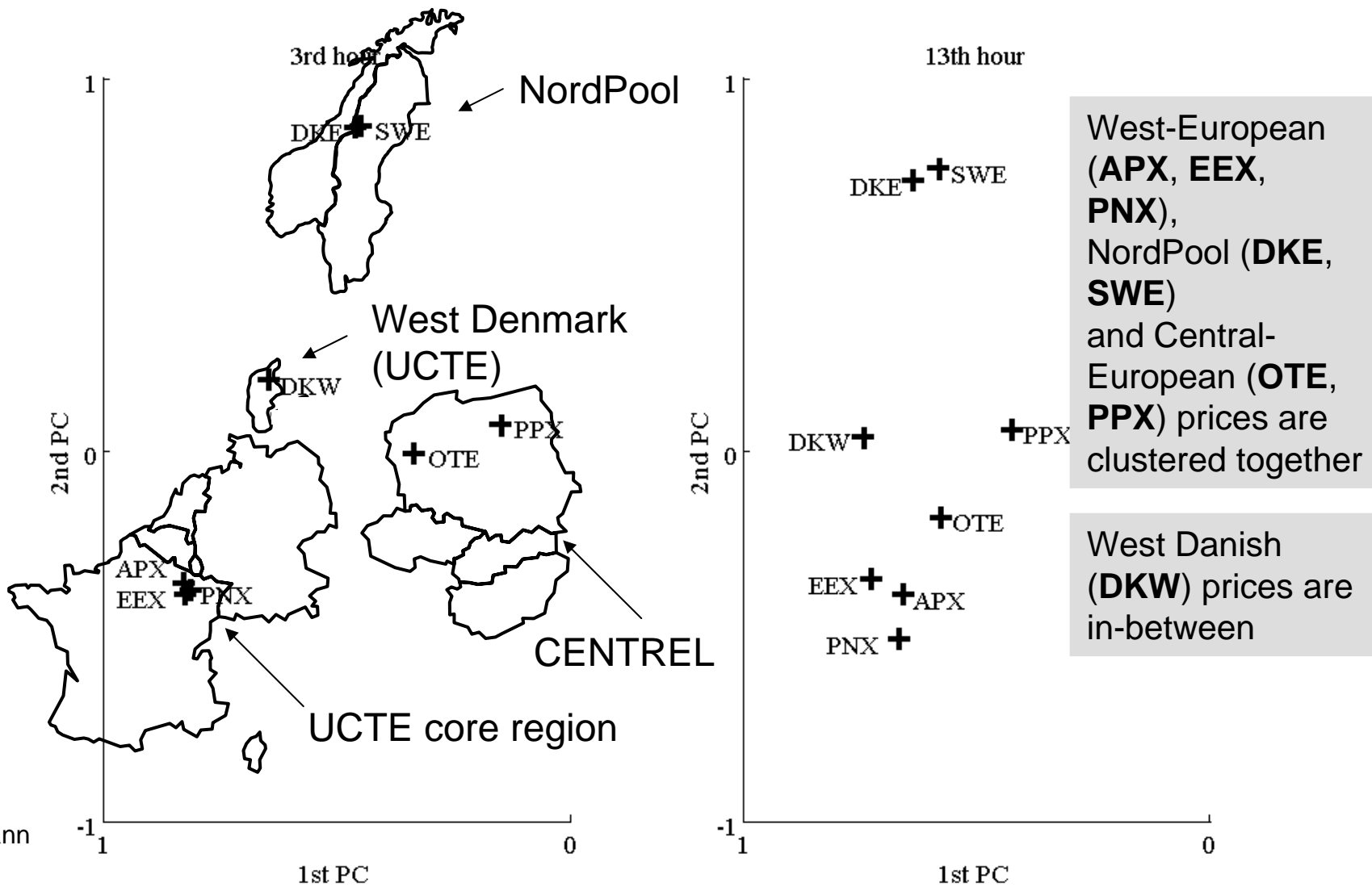

Timing of cross border auctions and spot markets

	Cross Border Auctions		Power Exchanges		
	EON-TenneT (EEX-APX)	EON-ELTRA (EEX-DKW)	APX	Elspot (NordPool)	EEX
Available capacity known to market participants	8:30 <i>Bid for 100 MW at 5€</i>	9:00			
End of bidding	9:00	9:30	10:30 <i>Offer 100 MW at 50€</i>	12:00	12:00 <i>Bid for 100 MW at 40€</i>
Publication of Results	9:30	10:00	11:00	12:00	12:15

Transmission Auction Results

EON => ELTRA

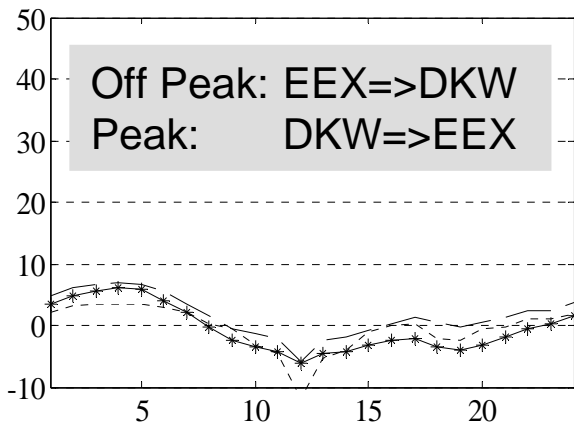

EON=>ELKRAFT

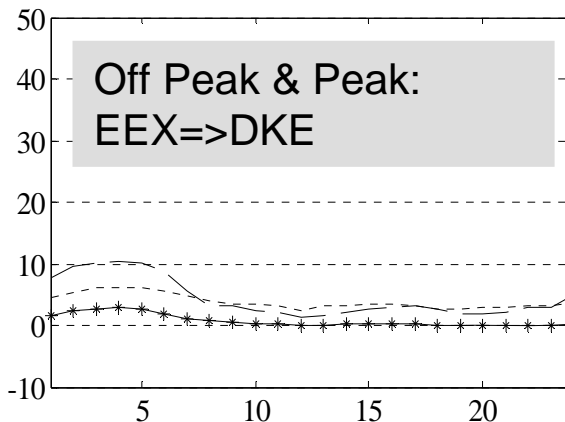

EON =>TenneT

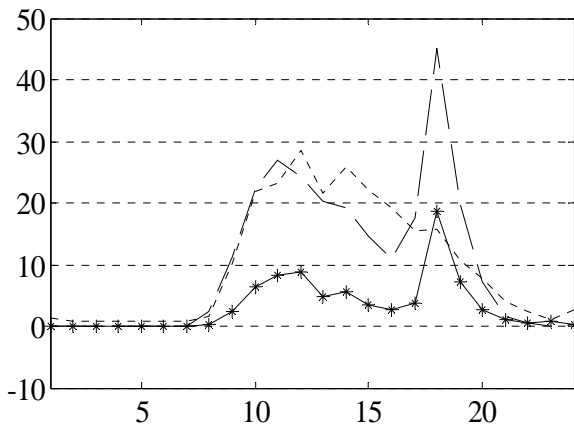

RWE =>TenneT

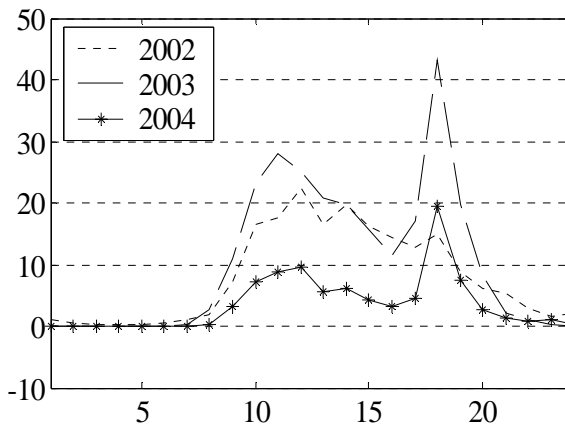

Off Peak: Price is zero on average.

Peak: High price for exporting power from EEX=>APX

Prices in €/MWh

1. Aim of the Study and Literature
2. Data
- 3. Method**
4. Results
5. Conclusion

Law of One Price

$$p_{EEX,t} + \text{transm}_{EEX \rightarrow APX,t} = p_{APX,t} + \text{transm}_{APX \rightarrow EEX,t}$$

The time varying coefficient framework

$$y_t = \alpha_t \cdot x_t + \epsilon_t$$

$$\alpha_t = \alpha_{t-1} + u_t$$

with

$$y_t = p_{i,t}$$

$$x_t = p_{j,t} + \text{transm}_{i \rightarrow j,t} - \text{transm}_{j \rightarrow i,t}$$

$$i, j = \text{APX, EEX, DKE, DKW}$$

$$\epsilon_t \sim N(0, \sigma_\epsilon^2) \quad \text{and} \quad u_t \sim N(0, \sigma_u^2) \quad \text{white noise process}$$

1. Aim of the Study and Literature
2. Data
3. Method
- 4. Results**
5. Conclusion

Time variant coefficient (α_t)

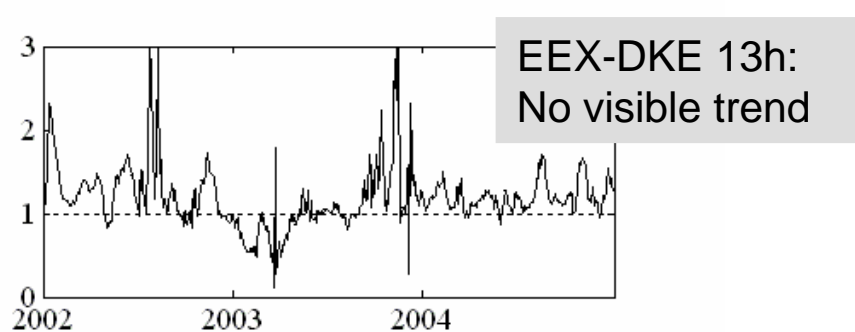
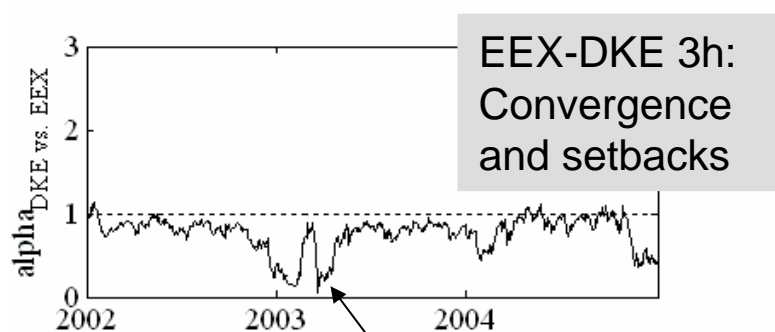
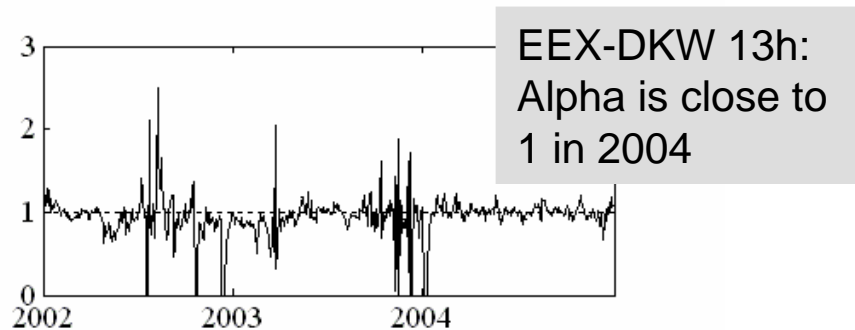
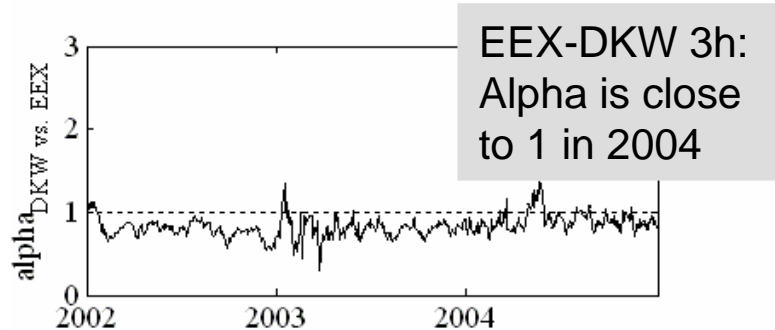
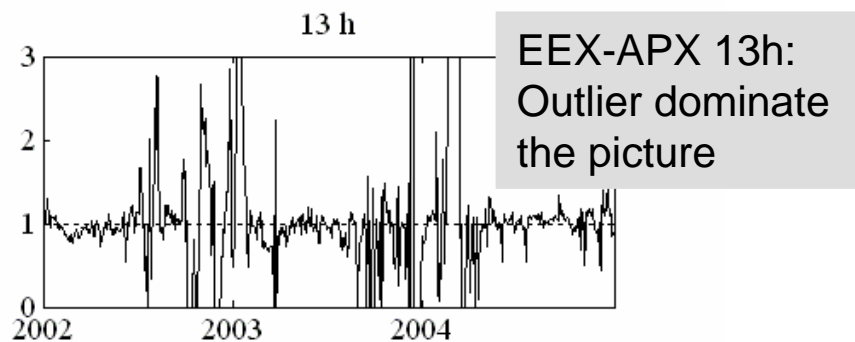
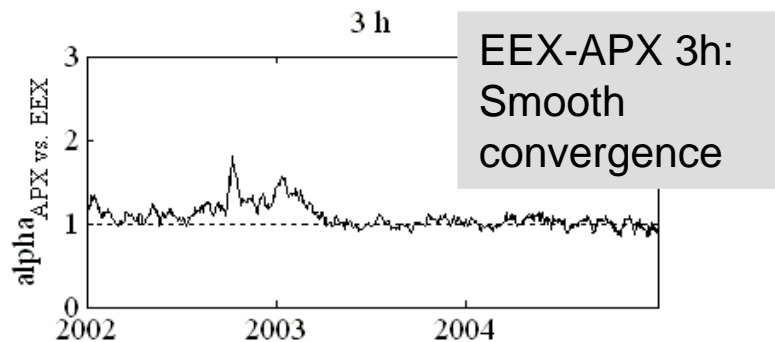

Kontek line closure

Proximity indices (γ_t) and convergence indicator (θ)

$$\gamma_t = \begin{cases} \hat{\alpha}_t & \text{if } \hat{\alpha}_t < 1 \\ 1/\hat{\alpha}_t & \text{if } \hat{\alpha}_t \geq 1 \end{cases}$$

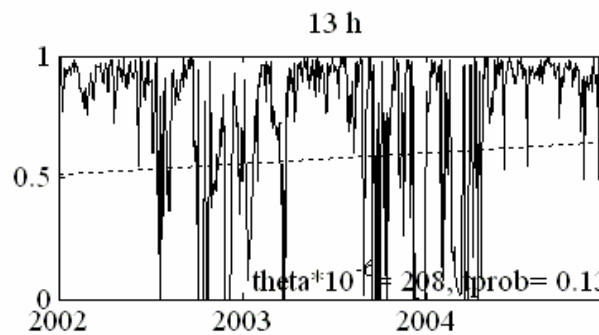
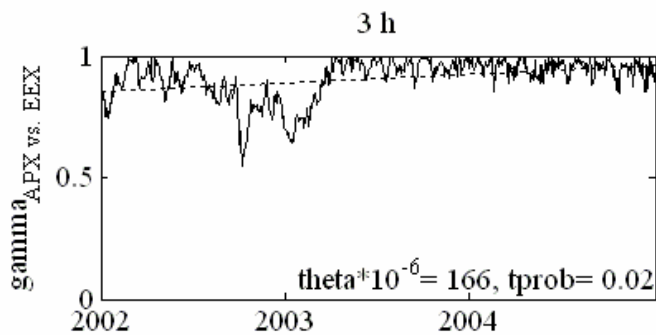

APX-EEX

- Convergence towards arbitrage-freeness in off-peak.
- No significant convergence in peak due to outliers

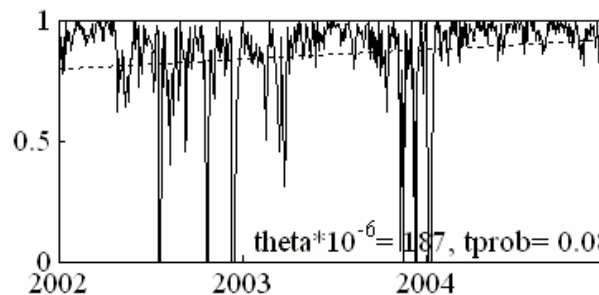
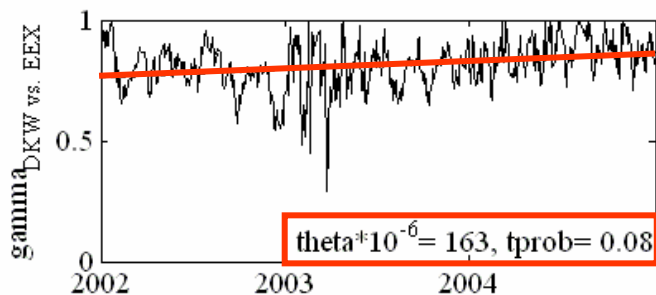

DKW-EEX

- significant convergence in peak and off-peak.

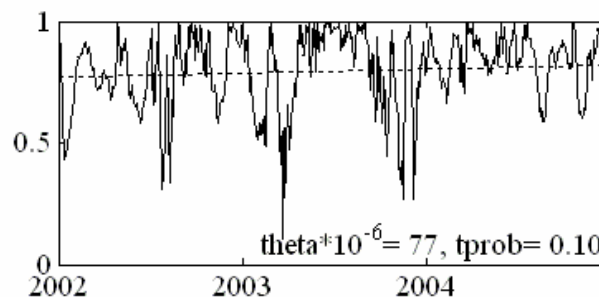
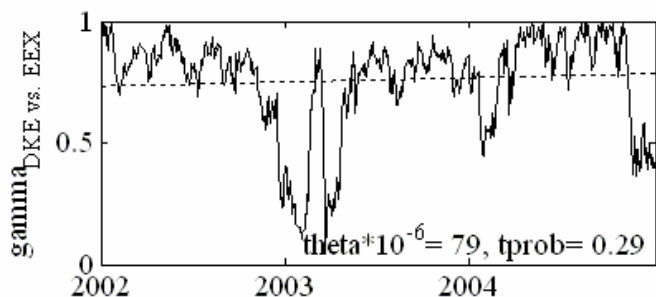

DKE-EEX

- No significant convergence in peak and off-peak.

Growth and significance of the convergence indicator 2002-2004

	EON - TenneT (EEX-APX)			EON - ELTRA (EEX-DKE)			EON - Elkraft (EEX-DKW)		
	tprob	theta 10 ⁻⁶	incpt	tprob	theta 10 ⁻⁶	incpt	tprob	theta 10 ⁻⁶	incpt
1h	0,06	0,09	0,90	0,21	0,10	0,81	0,09	0,10	0,86
3h	0,02	0,17	0,85	0,29	0,08	0,73	0,08	0,16	0,76
5h	0,03	0,18	0,83	0,36	0,00	0,74	0,13	0,13	0,76
7h	0,01	0,19	0,81	0,19	0,11	0,83	0,07	0,14	0,85
9h	0,10	0,20	0,74	0,18	0,02	0,83	0,09	0,12	0,84
11h	0,31	-1,24	-0,90	0,19	0,02	0,8	0,08	0,21	0,78
13h	0,13	0,21	0,51	0,10	0,08	0,77	0,08	0,19	0,80
15h	0,26	0,18	0,30	0,15	0,04	0,82	0,11	0,11	0,84
17h	0,25	-6,48	-7,12	0,20	0,04	0,85	0,06	0,13	0,87
19h	0,74	-5,88	-0,19	0,18	0,03	0,84	0,08	0,15	0,84
21h	0,07	0,13	0,85	0,17	0,08	0,83	0,09	0,10	0,89
23h	0,03	0,14	0,88	0,13	0,13	0,84	0,06	0,15	0,86

Number of hours with significant price convergence

EON - TenneT (EEX-APX)	EON - ELTRA (EEX-DKE)	EON - Elkraft (EEX-DKW)
12	0	19

1. Aim of the Study and Literature
2. Data
3. Method
4. Results
- 5. Conclusion**

Conclusion 1

- **West Danish and German** prices converged significantly for more than half of the hours of the day.
- This effect can be attributed to the increasing efficiency of cross border auctions, since the spot price differential remained.
- Since already the initial level of arbitrage possibilities in 2002 between both countries was low, the markets now determine almost efficient prices.

Conclusion 2

- **Dutch and German** prices converged significantly for half of the hours of the day.
- The convergence occurs mainly in the off-peak, whereas no convergence exists in the peak periods of the day.
- This might be explained by the enormous price spikes.

Conclusion 3

- **East Danish and German** prices did not exhibit convergence.
- Possible explanations:
 - Asynchronously operating transmission systems with different production structures (UCTE and Nordel)
 - Existence of only one interconnection, which has been subject to various closures in the sample period.
 - Auction design and market power might also play a role.

Conclusion 4

- Convergence seems to take place more steadily than stepwise. This indicates that this process is driven by slow adaptation of market players to framework changes (learning).
- At least at the day ahead markets, the introduction of explicit auctions increases efficiency over time (compared to non-market based congestion management methods)